

ø1.75 (over thread)

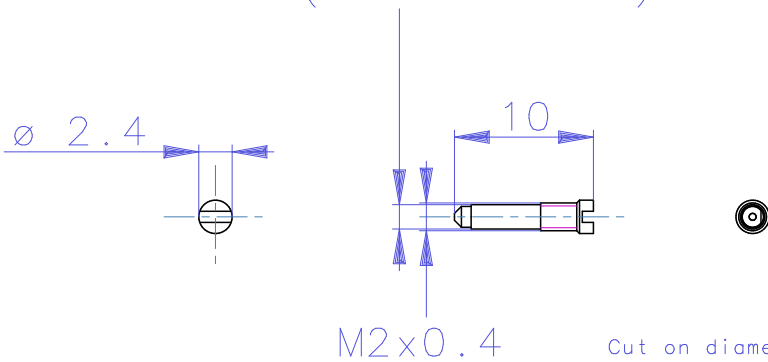

Cut on diameter 1.5mm is for the glue escaping, can be on any side relative to the screwdriver slot

Part #	0353-99-23		Description	Guide pin, threaded	
Material	Stainless Steel 18-8		Serial No.		
Finish			Assembly No.		
Weight(g)	0.2		Date		
Surface			Notes	Cut DIA 1.75 over M2x0.4 thread	
<small>Copyright (c) 2011 Elphel, Inc. Permission is granted to copy, distribute and/or modify this document under the terms of the GNU Free Documentation License, Version 1.3 or any later version published by the Free Software Foundation; with no Invariant Sections, no Front-Cover Texts, and no Back-Cover Texts. A copy of the license is included in the section entitled "GNU Free Documentation License".</small>					