

Copyright (c) 2009 Elphel, Inc.
 Permission is granted to copy, distribute and/or modify this document
 under the terms of the GNU Free Documentation License, Version 1.3
 or any later version published by the Free Software Foundation;
 with no Invariant Sections, no Front-Cover Texts, and no Back-Cover Texts.
 A copy of the license is included in the section entitled "GNU
 Free Documentation License".

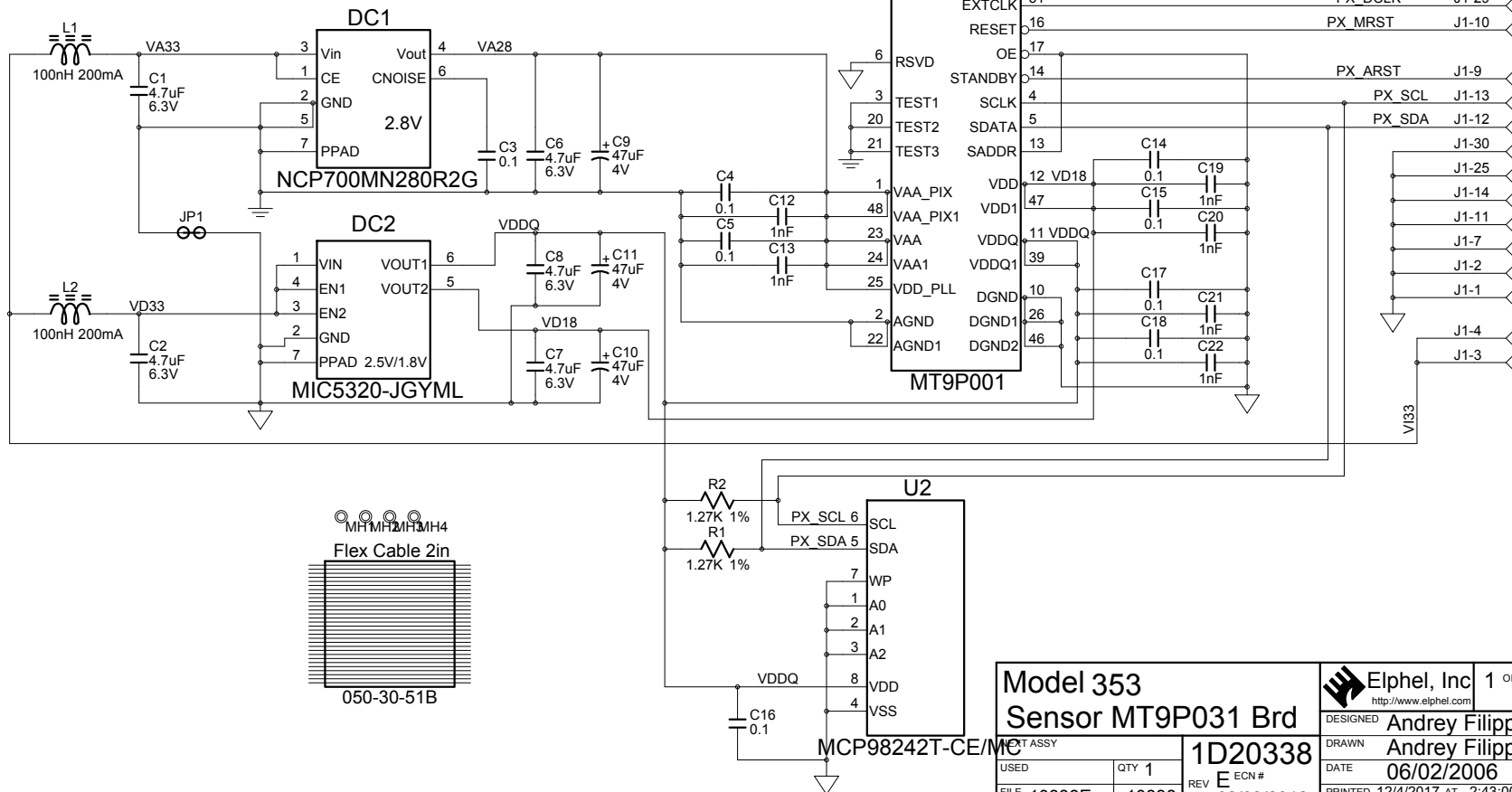

Model 353		Elphel, Inc 1 of 1 <small>http://www.elphel.com</small>	
Sensor MT9P031 Brd		DESIGNED Andrey Filippov	
PART ASSY		DRAWN Andrey Filippov	
USED	QTY 1	1D20338	
FILE 10338E	10338	REV E	ECN #
DATE 02/03/2012		DATE 06/02/2006	
PRINTED 12/4/2017 AT 2:43:00 PM			

SUB-ASSEMBLY															
USAGE	#		NO.					RELEASE DATE	02/03/12	P/L	REV.	REV.	Units to	Total	Cost per
353	1		TITLE	Model 353 Sensor MT9P031 Brd PCB Assembly 10338				JOB#	N/A	6/2/2006	E	2/3/2012	1	\$67.60	\$67.60
# TO	MFGR	1				WORK ORDER #	N/A								
NEXT	ASSY	4A-?????				NON STANDARD NOTATIONS									
DESIGNATOR	ITEM	QTY	EXT	STK	ROHS	DESCRIPTION	PART #	MANUFAC	VENDOR	VENDOR	PURCH	UNIT	TOTAL	NEW	
NUMBER	#	REQ	QTY	CHK			#	TURER	VENDOR	PART #	QTY	PRICE	TOTAL	STOCK	
Related Documents															
	0.5	1	1			Schematic 10338e (10338), Model 353	1D20338 Rev.E	Designed by Andrey Filippov							
	20	1	1			Fabrication (10338), Model 353	4F20338 Rev.E								
	21	1	1			Artwork (10338), Model 353	4G20338 Rev.E								
Integrated Circuits															
U1	40	1	1			5 Megapixel (2592x19545) 1/2.5" CMOS Image Sensor, 2.8V , MICRONILCC-48-10	MT9P001	Micron	Edge Electronics		1	45	45	0	
U2	41	1	1		Y	I2C 2Kb EEPROM with Temperature Sensor, TDFN-8	MCP98242T-CE/MC	Microchip	Digi-Key	MCP98242T-CE/MCCT-ND	1	1.06	1.06	0	
Power Supply Modules															
DC2	42	1	1		Y	Dual uCap ULDO Voltage Regulator, 1.6mm x 1.6mm, 2.5V/1.8V, 2.5V, 150mA , MLF-6, marked as AJG	MIC5320-JGYML	Micrel	Digi-Key	576-1568-1-ND	1	1.68	1.68	0	
DC1	43	1	1			Ultra low Noise BiCMOS Voltage Regulator, 2.8V, 200mA , DFN-6, marked as LBF	NCP700MN280R2G	ON Semiconductor	Digi-Key	NCP700MN280R2GOSCT-ND	1	1.09	1.09	0	
Resistors															
R1-R2	44	2	2		Y	Resistor, 1.27KΩ, ±1% , SMD 0201, marked as 1271	ERJ-1GEF1271C	Panasonic	Digi-Key	P1.27KABCT-ND	10	0.11	1.1	8	
Capacitors															
C9-C11	45	3	3		Y	Low profile Tantalum Chip Capacitor, ESR=1.1 Ohm, 47µF, 4V , 3216-08	F950G476MQAAQ2	Nichicon	Digi-Key	493-2891-1-ND	10	0.578	5.78	7	
C3-C5, C14-C18	46	8	8		Y	Capacitor, Ceramic Chip, 0.1µF, 6.3V , C-0201D	ECJ-ZEB0J104M	Panasonic	Digi-Key	PCC2336CT-ND	10	0.13	1.3	2	
C1-C2, C6-C8	47	5	5		Y	Capacitor, Ceramic Chip, 20%, 4.7µF, 6.3V , C-0402	ECJ-0EB0J475M	Panasonic	Digi-Key	PCC2475CT-ND	10	0.29	2.9	5	
C12-C13, C19-C22	48	6	6		Y	Capacitor, Ceramic Chip, 1nF, 25V , C-0201	ECJ-ZEB1E102K	Panasonic	Digi-Key	PCC2130CT-ND	10	0.075	0.75	4	

DESIGNATOR	ITEM	QTY	EXT	STK	ROHS		PART	MANUFAC	VENDOR	VENDOR	PURCH	UNIT		NEW
NUMBER	#	REQ	QTY	CHK		DESCRIPTION	#	TURER	VENDOR	PART #	QTY	PRICE	TOTAL	STOCK
-----	---	---	----	---	----	-----	-----	-----	-----	-----	-----	----	----	----
						Inductors and LC filters								
L1-L2	49	2	2		Y	SMD Inductor, DCR=1.5 Ohm, 100nHn , 200mA , SMD 0402	HK1005R10J-T	Taiyo Yuden	Digi-Key	587-1531-1-ND	2	0	0	0
-----	---	---	----	---	----	Connectors	-----	-----	-----	-----	-----	----	----	----
J1	50	1	1		Y	0.5 mm-Pitch Vertical Slide-Lock FPC Connector, 30 pos., FH1230S05SV	FH12-30S-0.5SV-55	Hirose	Digi-Key	HFL130CT-ND	1	3.11	3.11	0
-----	---	---	----	---	----	Sockets and Matching Parts	-----	-----	-----	-----	-----	----	----	----
XJ1	51	1	1			Flex Cable, 0.5 mm pitch, 30 conductors, 2 in long, 050-30-51B	050-30-51B	Parlex	Digi-Key	HFF-30U-02-ND	1	3.83	3.83	0